

CSCI 480 Computer Graphics  
Lecture 2

# Basic Graphics Programming

Graphics Pipeline  
OpenGL API  
Primitives: Lines, Polygons  
Attributes: Color  
Example  
[Angel Ch. 2]

January 11, 2012  
Jernej Barbic  
University of Southern California

<http://www-bcf.usc.edu/~jbarbic/cs480-s12/>

# What is OpenGL

- A low-level graphics library (API) for 2D and 3D interactive graphics.
- Descendent of GL (from SGI)
- First version in 1992; now: 4.2 (2012)
- Managed by Khronos Group (non-profit consortium)
- API is governed by Architecture Review Board (part of Khronos)



# Where is OpenGL used

- CAD
- Virtual reality
- Scientific visualization
- Flight simulation
- Video games



# Graphics library (API)

- Intermediary between applications and graphics hardware

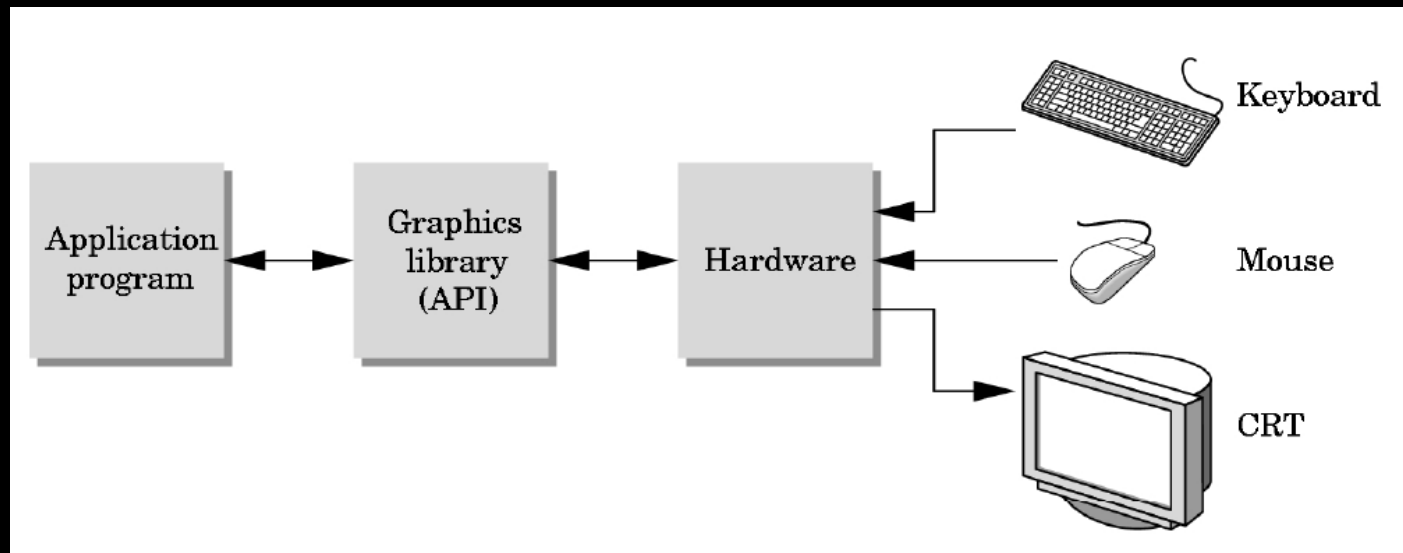

- Other popular APIs:
  - Direct3D (Microsoft)
  - OpenGL ES (embedded devices)
  - X3D (successor of VRML)

# OpenGL is cross-platform

- Same code works with little/no modifications
- Implementations:  
Windows, Mac, Linux: ships with the OS  
Linux: Mesa, a freeware implementation.

```
#if defined(WIN32) || defined(linux)
    #include <GL/gl.h>
    #include <GL/glu.h>
    #include <GL/glut.h>
#elif defined(__APPLE__)
    #include <OpenGL/gl.h>
    #include <OpenGL/glu.h>
    #include <GLUT/glut.h>
#endif
```

# How does OpenGL work

From the programmer's point of view:

1. Specify geometric objects
2. Describe object properties
  - Color
  - How objects reflect light

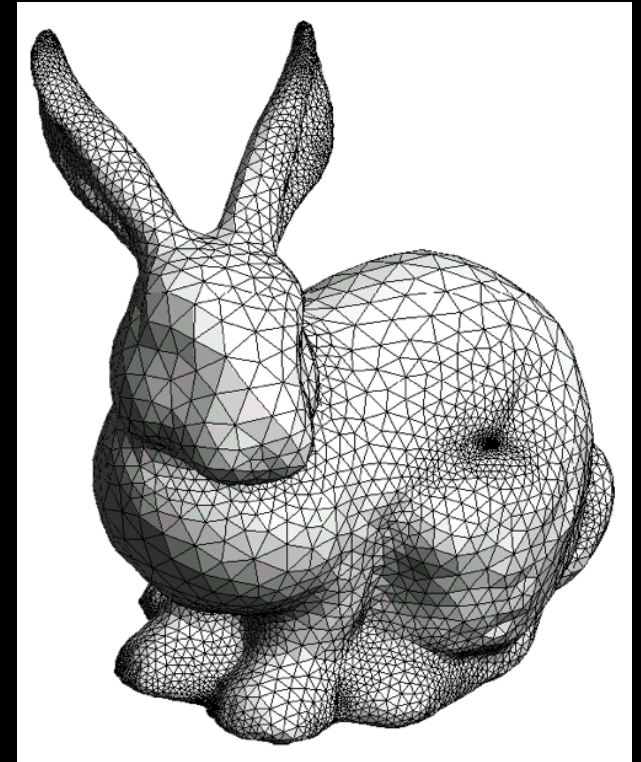

# How does OpenGL work (continued)

3. Define how objects should be viewed
  - where is the camera
  - what type of camera
4. Specify light sources
  - where, what kind
5. Move camera or objects around for animation

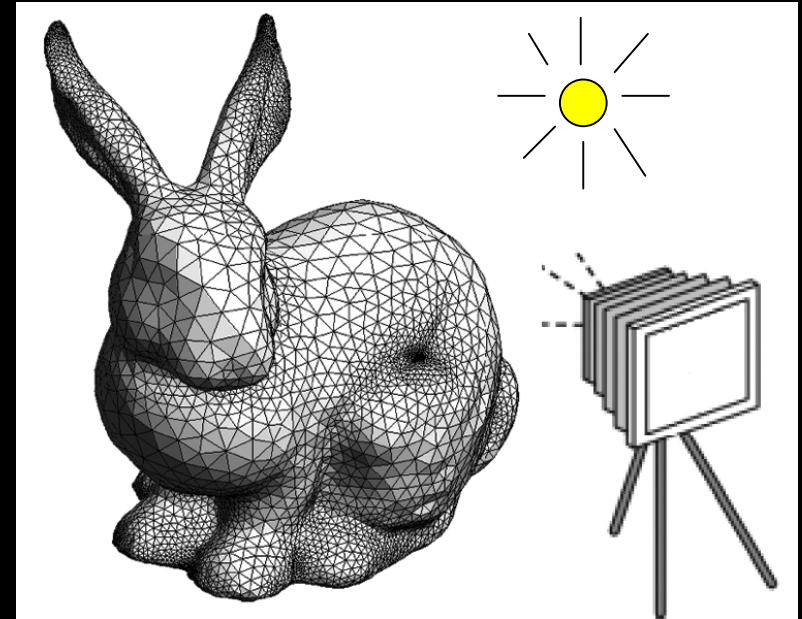

# The result

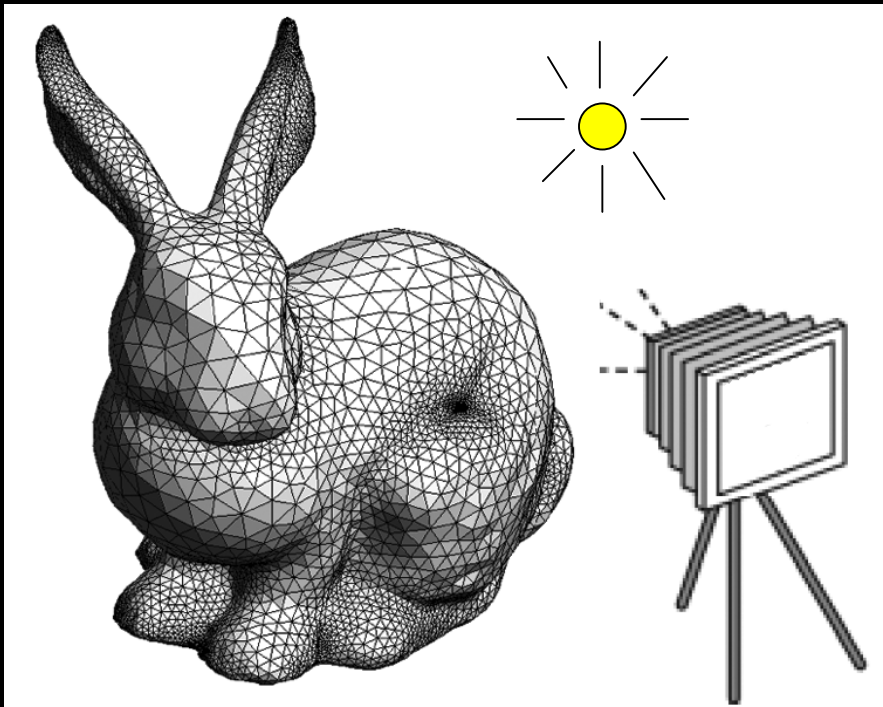

the result



# OpenGL is a state machine

State variables: color, camera position, light position, material properties...

These variables (the *state*) then apply to every subsequent drawing command.

They persist until set to new values by the programmer.

# OpenGL Library Organization

- GL (Graphics Library): core graphics capabilities
- GLU (OpenGL Utility Library): utilities on top of GL
- GLUT (OpenGL Utility Toolkit): input and windowing

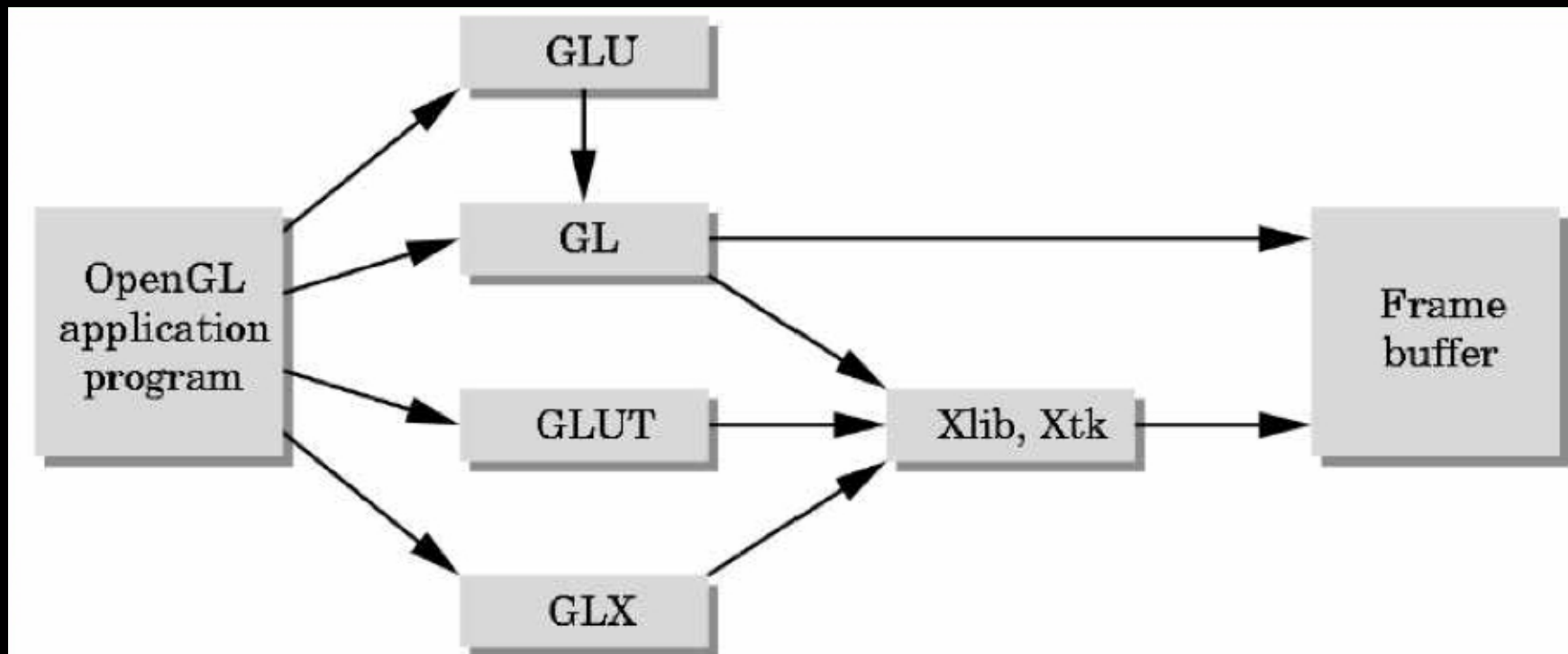

# Graphics Pipeline

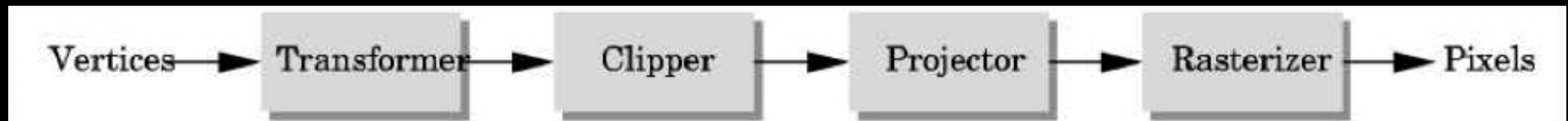

Primitives+  
material  
properties

Translate  
Rotate  
Scale

Is it visible  
on screen?

3D to 2D

Convert to  
pixels

Shown  
on the screen  
(framebuffer)

## OpenGL uses *immediate-mode rendering*

- Application generates stream of geometric primitives (polygons, lines)
- System draws each one into the framebuffer
- Entire scene redrawn anew every frame
- Compare to: off-line rendering (e.g., Pixar Renderman, ray tracers)

The pipeline is implemented by OpenGL, graphics driver and the graphics hardware

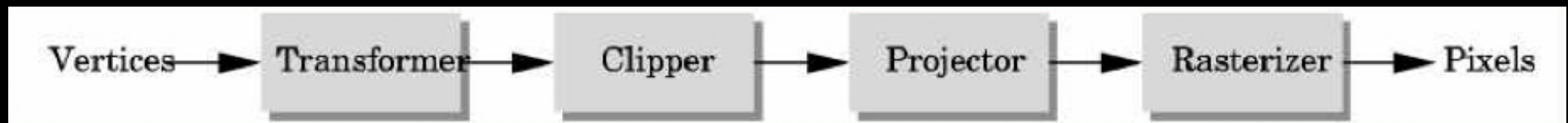

OpenGL programmer does not need to implement the pipeline.

However, pipeline is reconfigurable if needed

→ “shaders”

# Graphics Pipeline

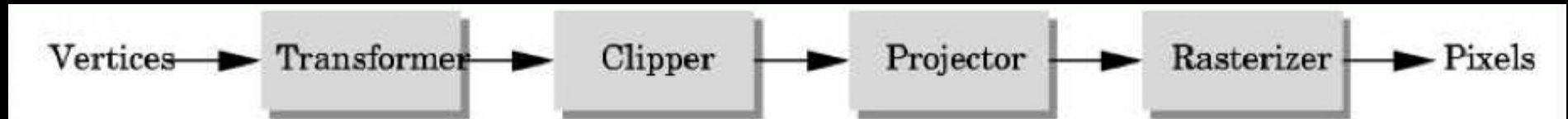

- Efficiently implementable in hardware (but not in software)
- Each stage can employ multiple specialized processors, working in parallel, busses between stages
- #processors per stage, bus bandwidths are fully tuned for typical graphics use
- Latency vs throughput

# Vertices

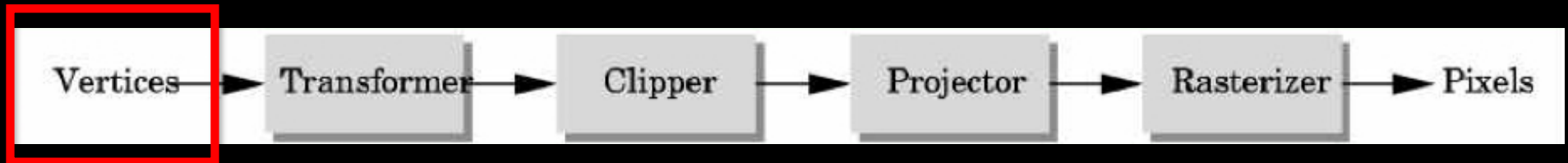

- Vertices in **world coordinates**
- `void glVertex3f(GLfloat x, GLfloat y, GLfloat z)`
  - Vertex (x, y, z) is sent down the pipeline.
  - Function call then returns.
- Use *GLtype* for portability and consistency
- `glVertex{234}{sfid}[v](TYPE coords)`

# Transformer

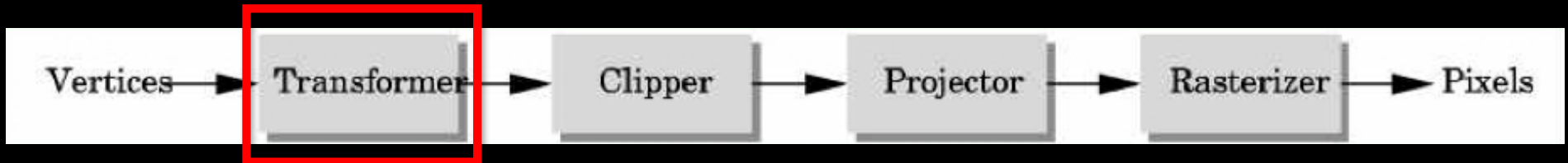

- Transformer in **world coordinates**
- Must be set **before** object is drawn!

```
glRotatef(45.0, 0.0, 0.0, -1.0);  
glVertex2f(1.0, 0.0);
```

- Complex [Angel Ch. 4]



# Clipper

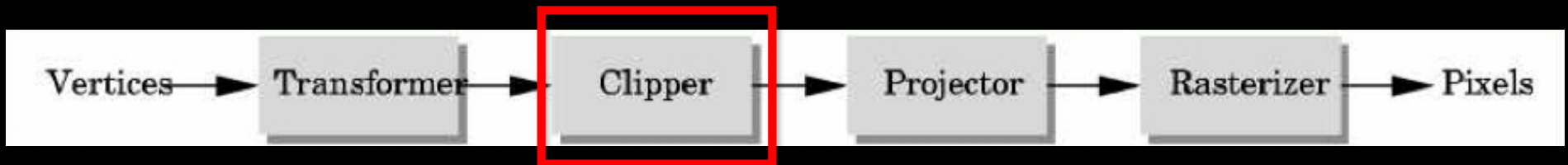

- Mostly automatic (must set viewport)

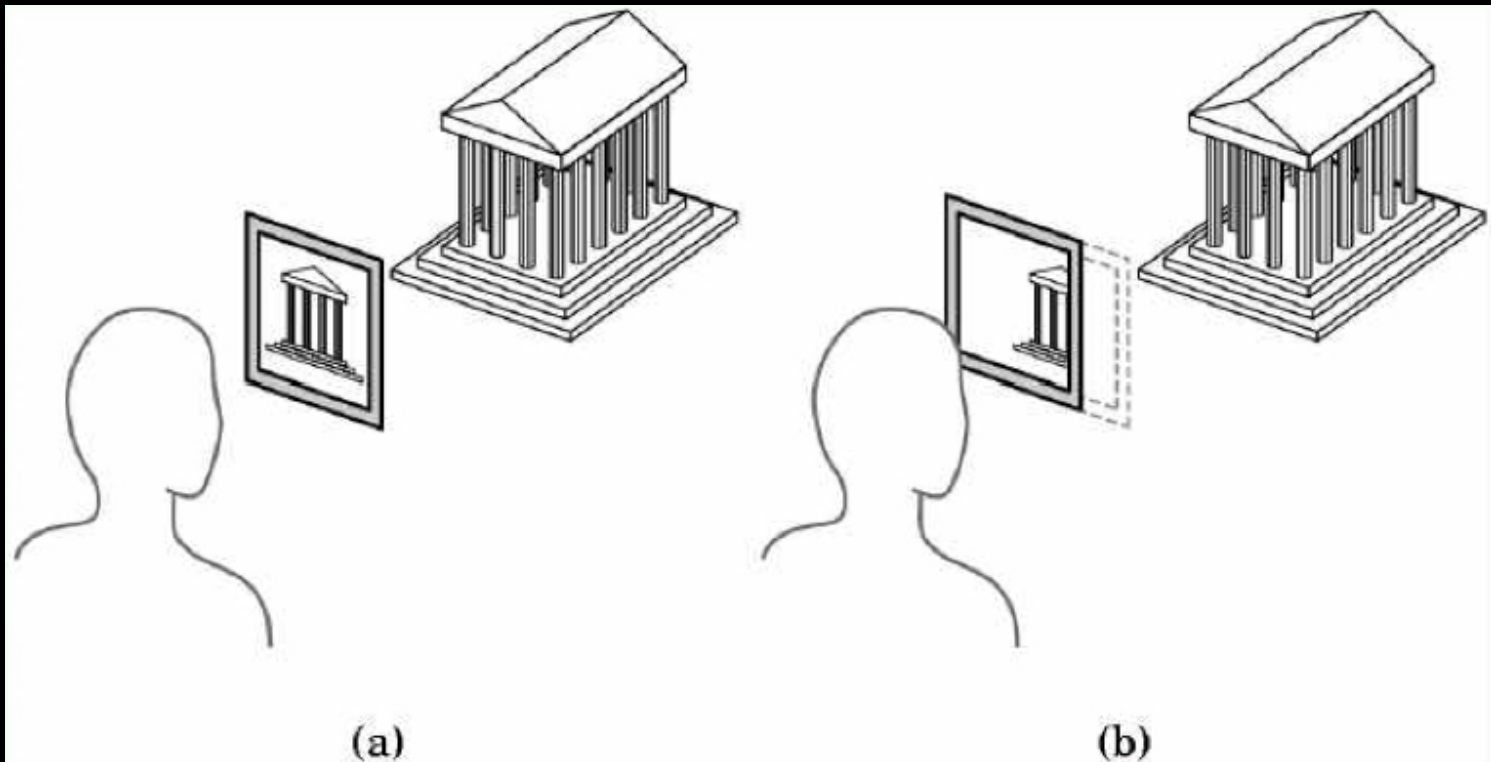

# Projector

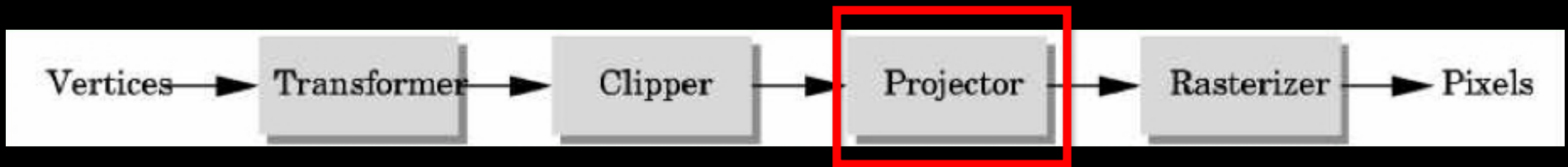

- Complex transformation [Angel Ch. 5]

Orthographic

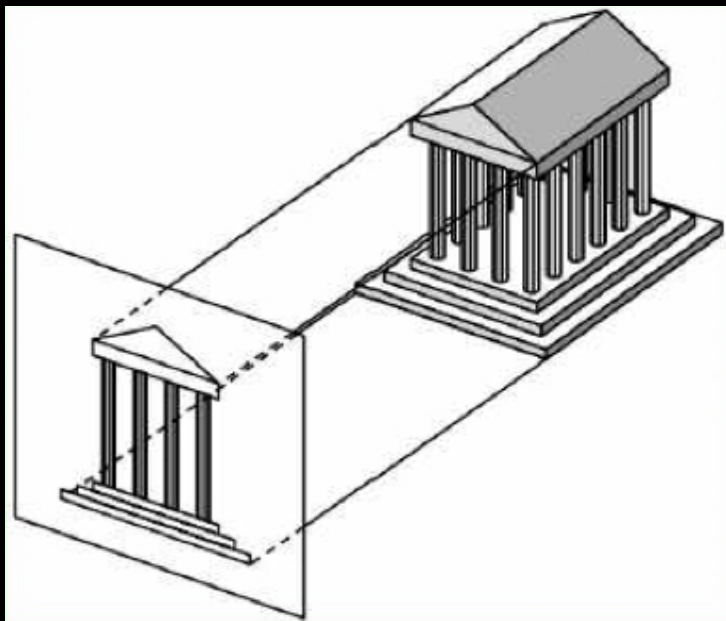

Perspective

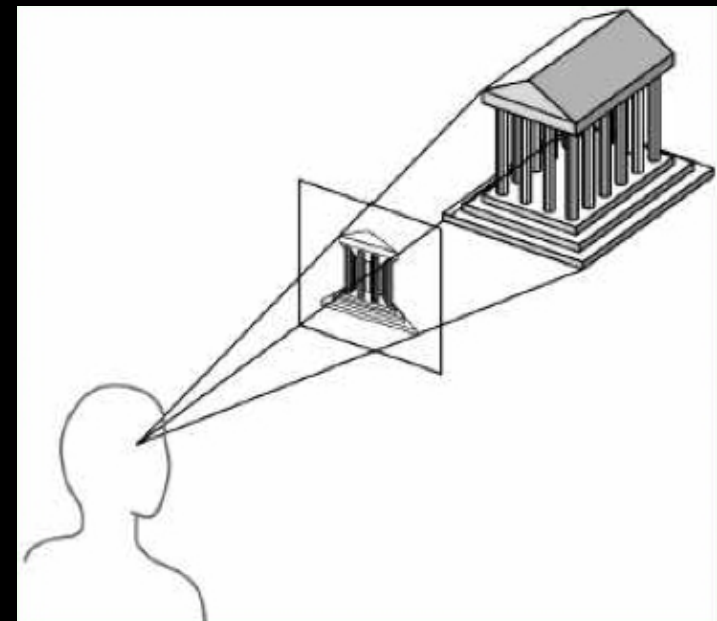

# Rasterizer

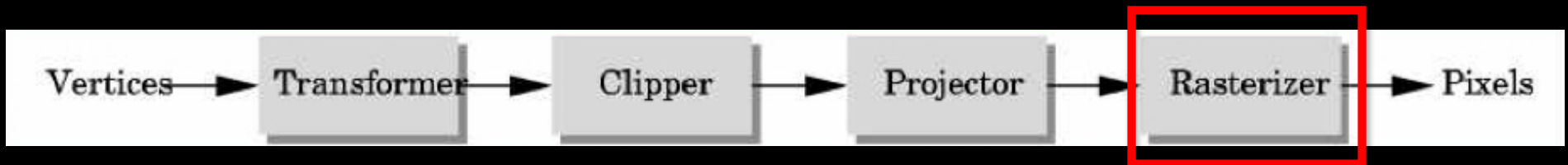

- Interesting algorithms [Angel Ch. 7]
- To **window coordinates**
- Antialiasing

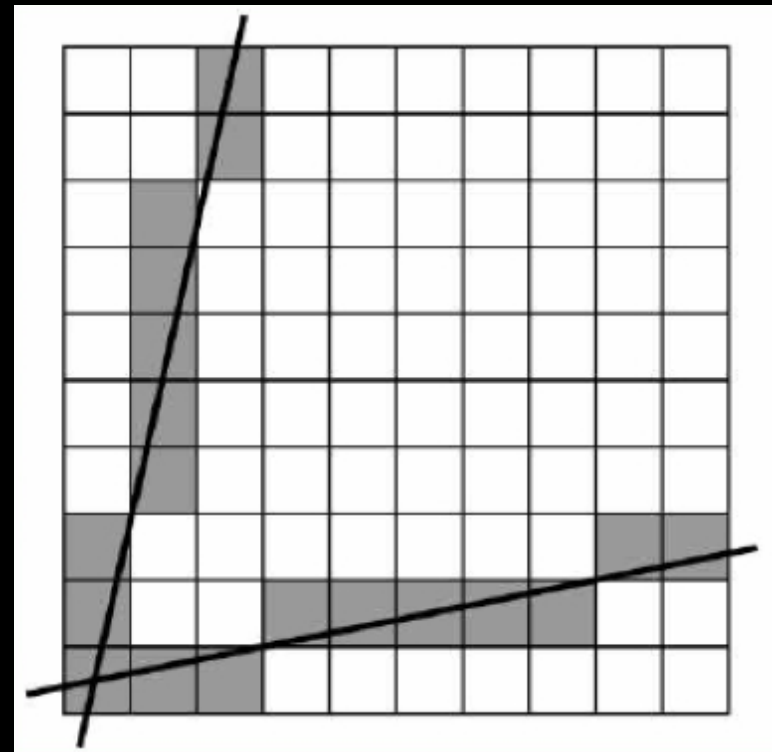

# Primitives

- Specified via vertices
- General schema

```
glBegin(type);  
    glVertex3f(x1, y1, z1);  
    ...  
    glVertex3f(xN, yN, zN);  
glEnd();
```

- *type* determines interpretation of vertices
- Can use glVertex2f(x,y) in 2D

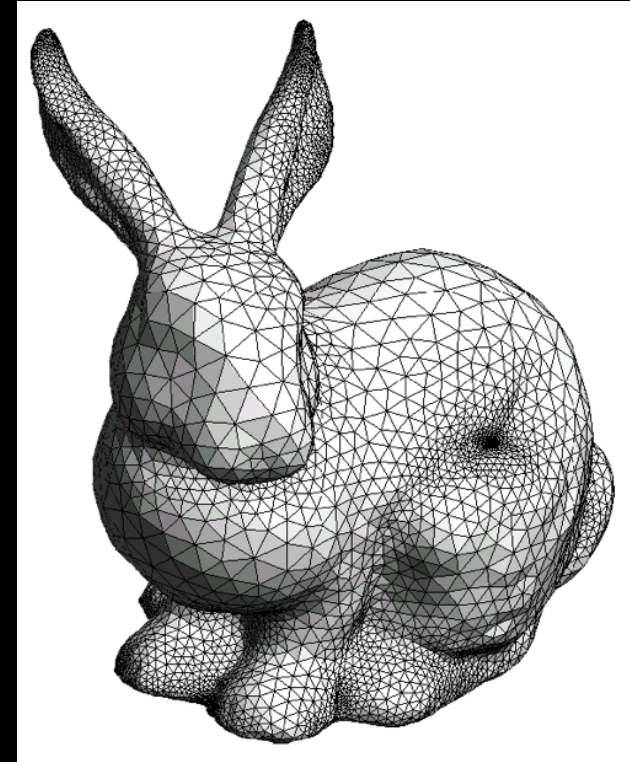

# Example: Draw Square Outline

- *Type* = GL\_LINE\_LOOP

```
glBegin(GL_LINE_LOOP);  
  glVertex3f(0.0, 0.0, 0.0);  
  glVertex3f(1.0, 0.0, 0.0);  
  glVertex3f(1.0, 1.0, 0.0);  
  glVertex3f(0.0, 1.0, 0.0);  
glEnd();
```

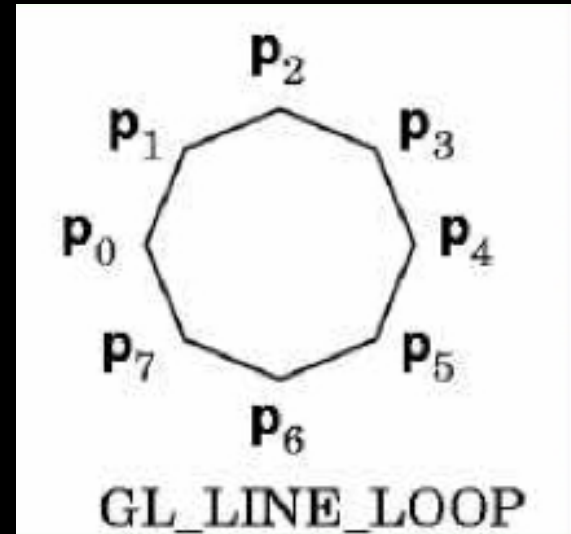

- Calls to other functions are allowed between glBegin(*type*) and glEnd();

# Points and Line Segments

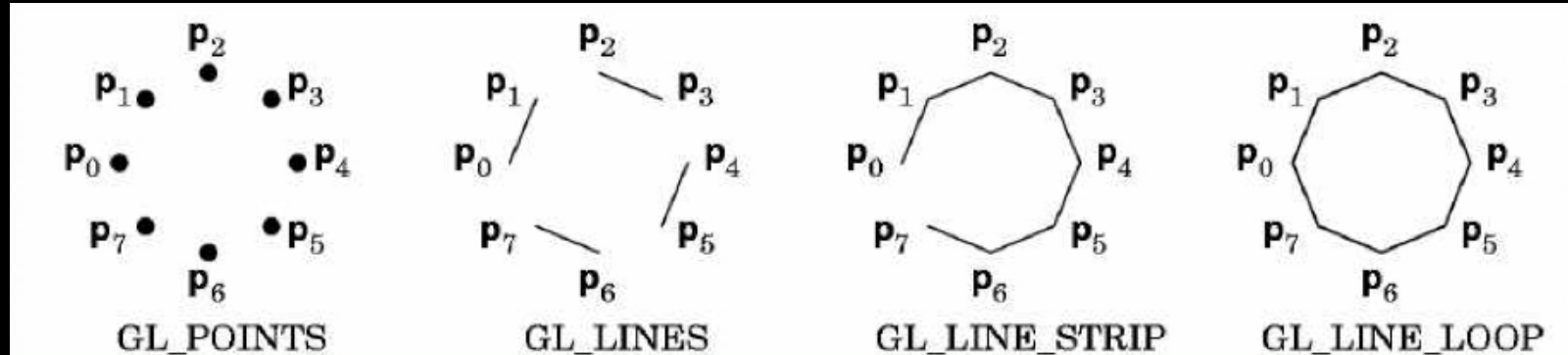

```
glBegin (GL_POINTS);  
  glVertex3f(...);  
  ...  
  glVertex3f(...);  
glEnd();
```

Draw points

# Polygons

- Polygons enclose an area

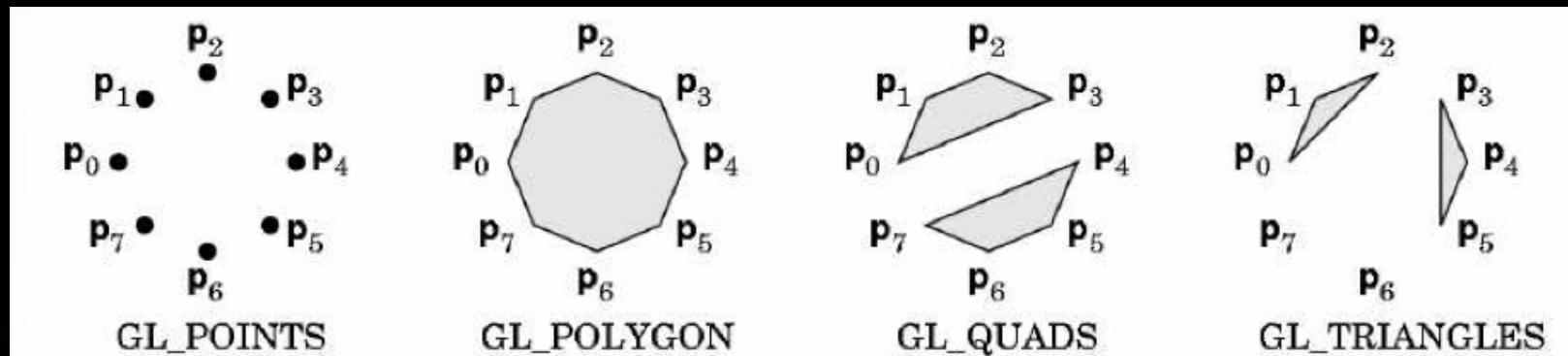

- Rendering of area (fill) depends on attributes
- All vertices must be in one plane in 3D

# Polygon Restrictions

- OpenGL Polygons must be **simple**
- OpenGL Polygons must be **convex**

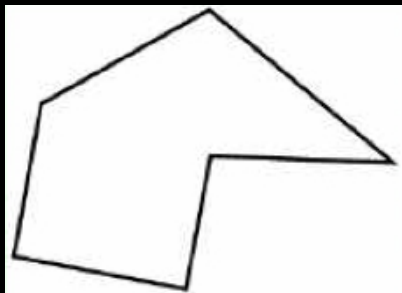

(a) simple, but not convex

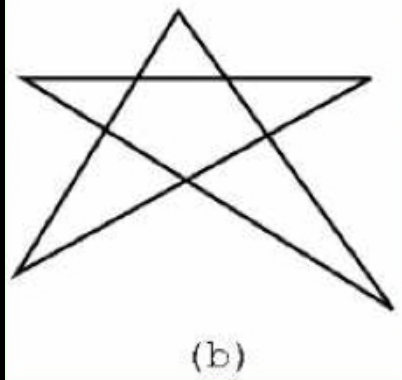

(b) non-simple

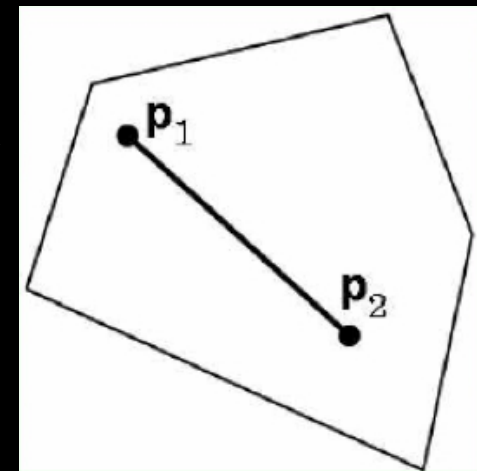

(c) convex



# Why Polygon Restrictions?

- Non-convex and non-simple polygons are expensive to process and render
- Convexity and simplicity is expensive to test
- Behavior of OpenGL implementation on disallowed polygons is “**undefined**”
- Some tools in GLU for decomposing complex polygons (tessellation)
- Triangles are most efficient

# Polygon Strips

- Efficiency in space and time
- Reduces visual artefacts

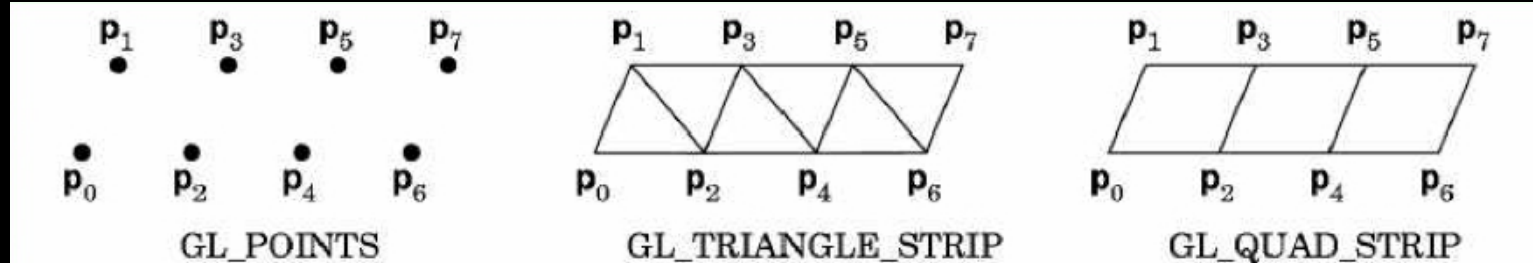

- Polygons have a front and a back, possibly with different attributes!

## Attributes:

color, shading and reflection properties

- Part of the OpenGL state
- Set before primitives are drawn
- Remain in effect until changed!

# Physics of Color

- Electromagnetic radiation
- Can see only tiny piece of the spectrum

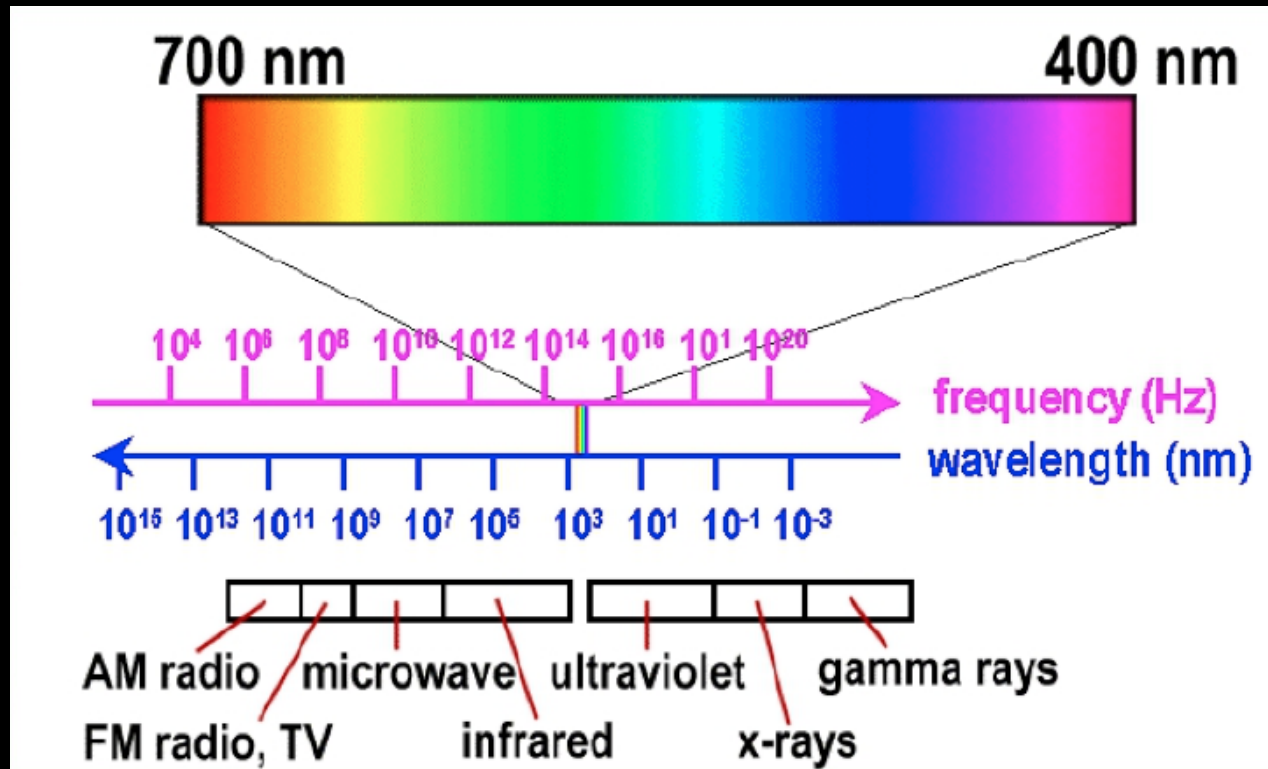

# Color Filters

- Eye can perceive only 3 basic colors
- Computer screens designed accordingly

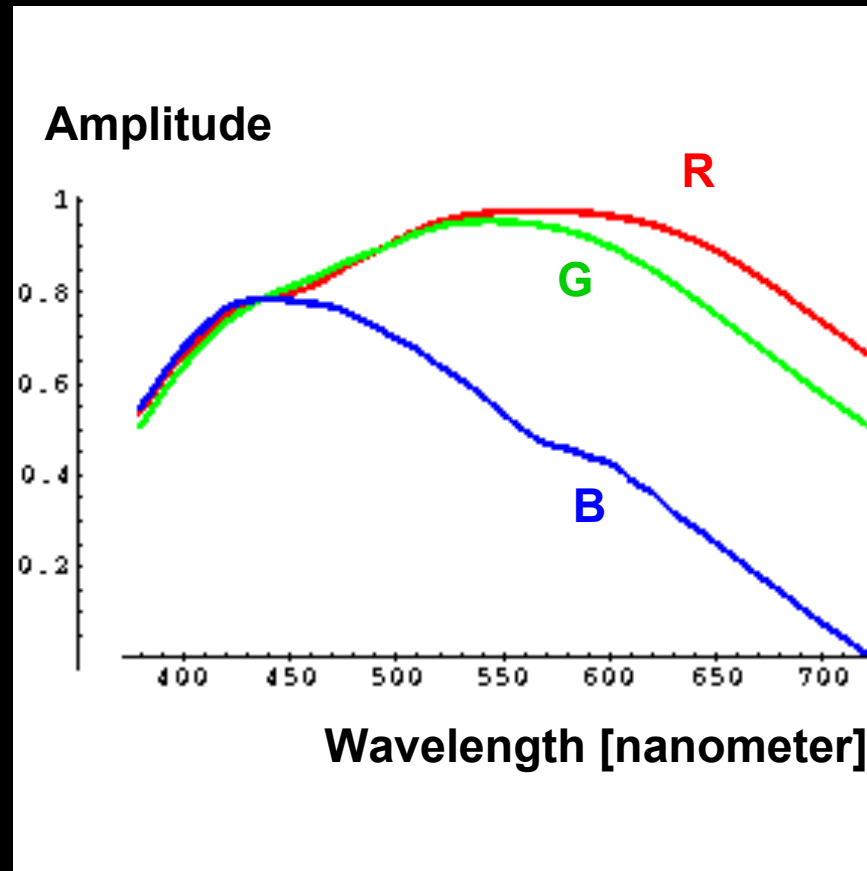

Source: Vos & Walraven

# Color Spaces

- RGB (Red, Green, Blue)
  - Convenient for display
  - Can be unintuitive (3 floats in OpenGL)
- HSV (Hue, Saturation, Value)
  - Hue: what color
  - Saturation: how far away from gray
  - Value: how bright
- Other formats for movies and printing

# RGB vs HSV

Gimp Color Picker

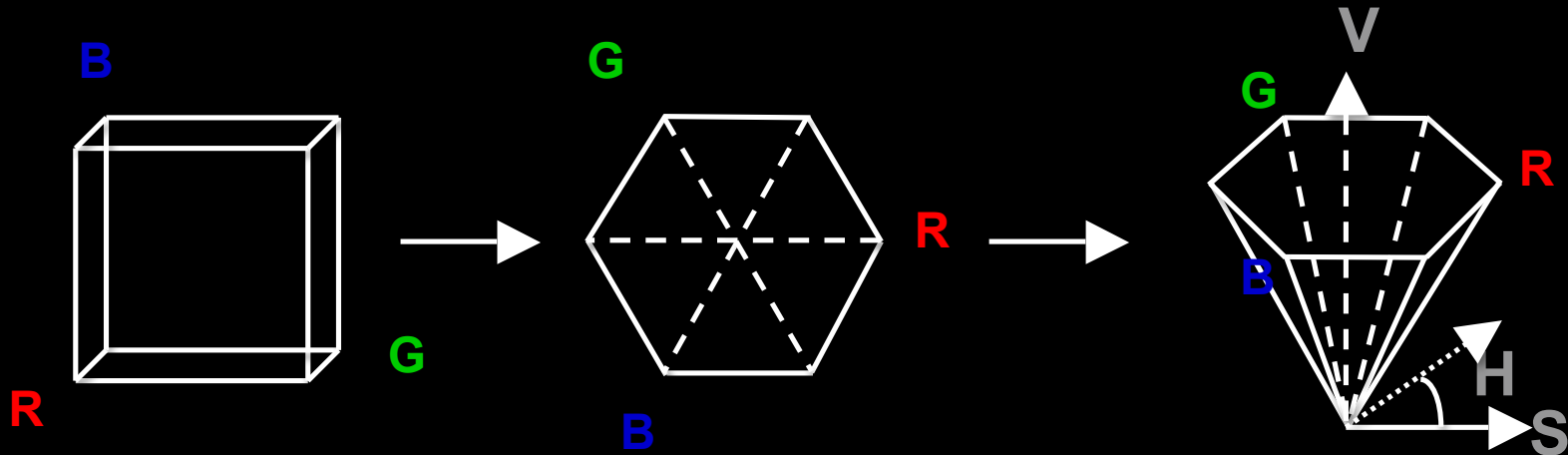
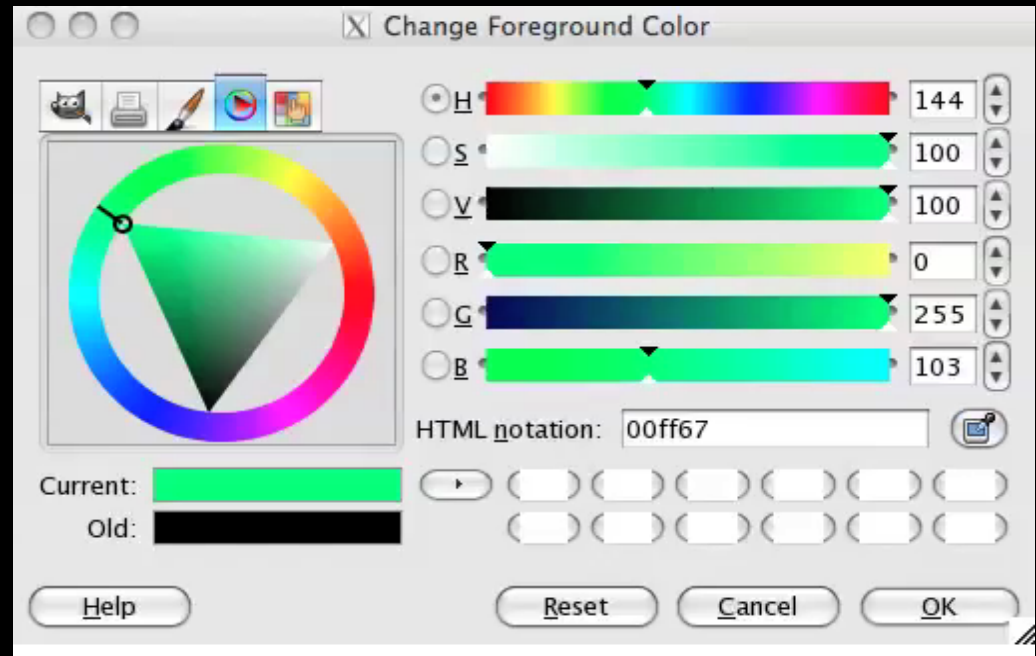

# Example: Drawing a shaded polygon

- Initialization: the “main” function

```
int main(int argc, char** argv)
{
    glutInit(&argc, argv);
    glutInitDisplayMode (GLUT_DOUBLE | GLUT_RGB);
    glutInitWindowSize (500, 500);
    glutInitWindowPosition (100, 100);
    glutCreateWindow (argv[0]);
    init ();
    ...
}
```



# GLUT Callbacks

- Window system independent interaction
- glutMainLoop processes events

```
...  
    glutDisplayFunc(display);  
    glutReshapeFunc(reshape);  
    glutKeyboardFunc (keyboard);  
    glutMainLoop();  
    return 0;  
}
```

# Initializing Attributes

- Separate in “init” function

```
void init(void)
{
    glClearColor (0.0, 0.0, 0.0, 0.0);

    /* glShadeModel (GL_FLAT); */
    glShadeModel (GL_SMOOTH);
}
```

# The Display Callback

- The routine where you render the object
- Install with `glutDisplayFunc(display)`

```
void display(void)
{
    glClear (GL_COLOR_BUFFER_BIT); /* clear buffer */
    setupCamera();                /* set up the camera */
    triangle ();                  /* draw triangle */
    glutSwapBuffers ();          /* force display */
}
```

# Drawing

- In world coordinates; remember state!

```
void triangle(void)
{
    glBegin (GL_TRIANGLES);
    glColor3f (1.0, 0.0, 0.0); /* red */
    glVertex2f (5.0, 5.0);
    glColor3f (0.0, 1.0, 0.0); /* green */
    glVertex2f (25.0, 5.0);
    glColor3f (0.0, 0.0, 1.0); /* blue */
    glVertex2f (5.0, 25.0);
    glEnd();
}
```

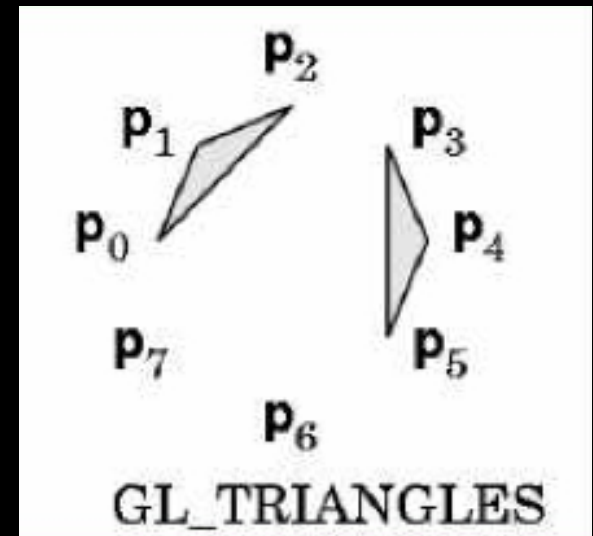

# The Image

`glShadeModel(GL_FLAT)`

color of last vertex

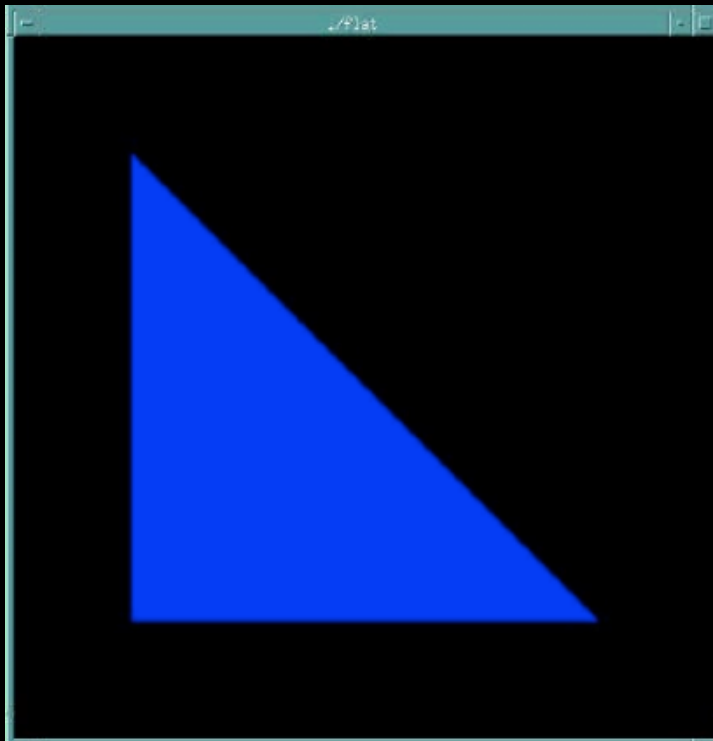

`glShadeModel(GL_SMOOTH)`

each vertex separate color  
smoothly interpolated

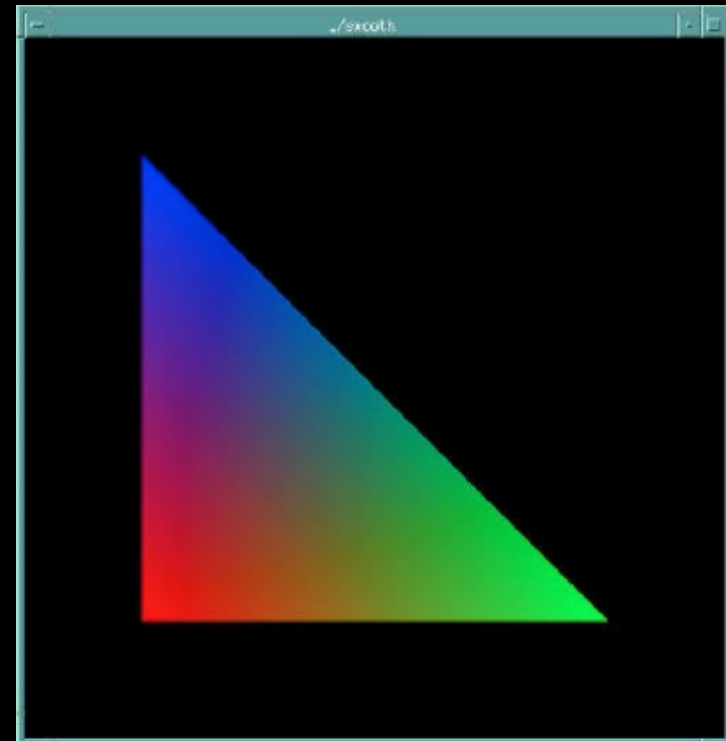

# Flat vs Smooth Shading

Flat Shading



Smooth Shading



# Projection

- Mapping world to screen coordinates

```
void reshape(int w, int h)
{
    glViewport (0, 0, (GLsizei) w, (GLsizei) h);
    glMatrixMode (GL_PROJECTION);
    glLoadIdentity ();
    if (w <= h)
        gluOrtho2D (0.0, 30.0, 0.0, 30.0 * (GLfloat) h/(GLfloat) w);
    else
        gluOrtho2D (0.0, 30.0 * (GLfloat) w/(GLfloat) h, 0.0, 30.0);
    glMatrixMode(GL_MODELVIEW);
}
```

# Orthographic Projection

- 2D and 3D versions
- `glOrtho2D(left, right, bottom, top)`
- In **world coordinates!**

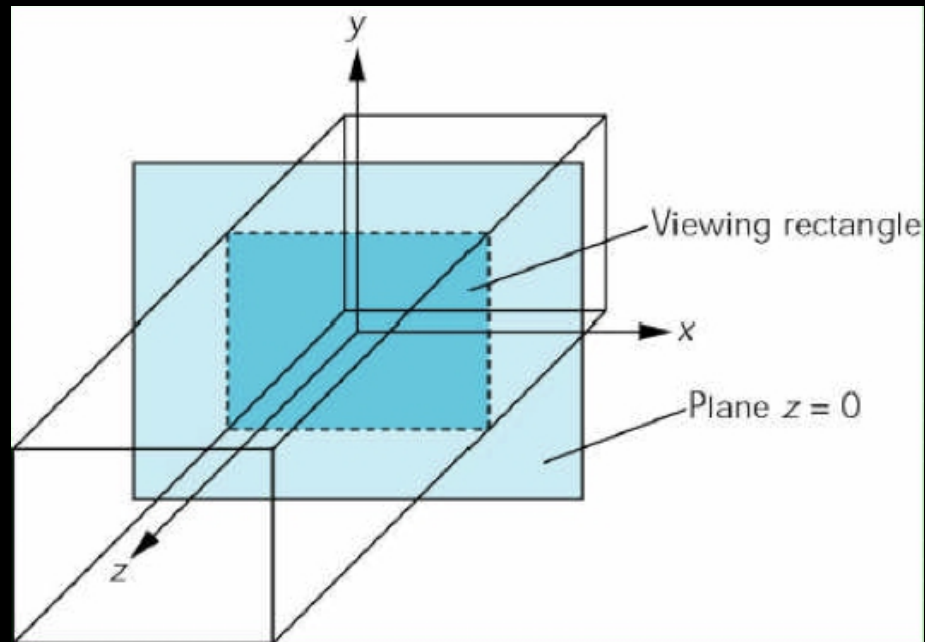



# Viewport

- Determines clipping in window coordinates
- `glViewport(x, y, w, h)`

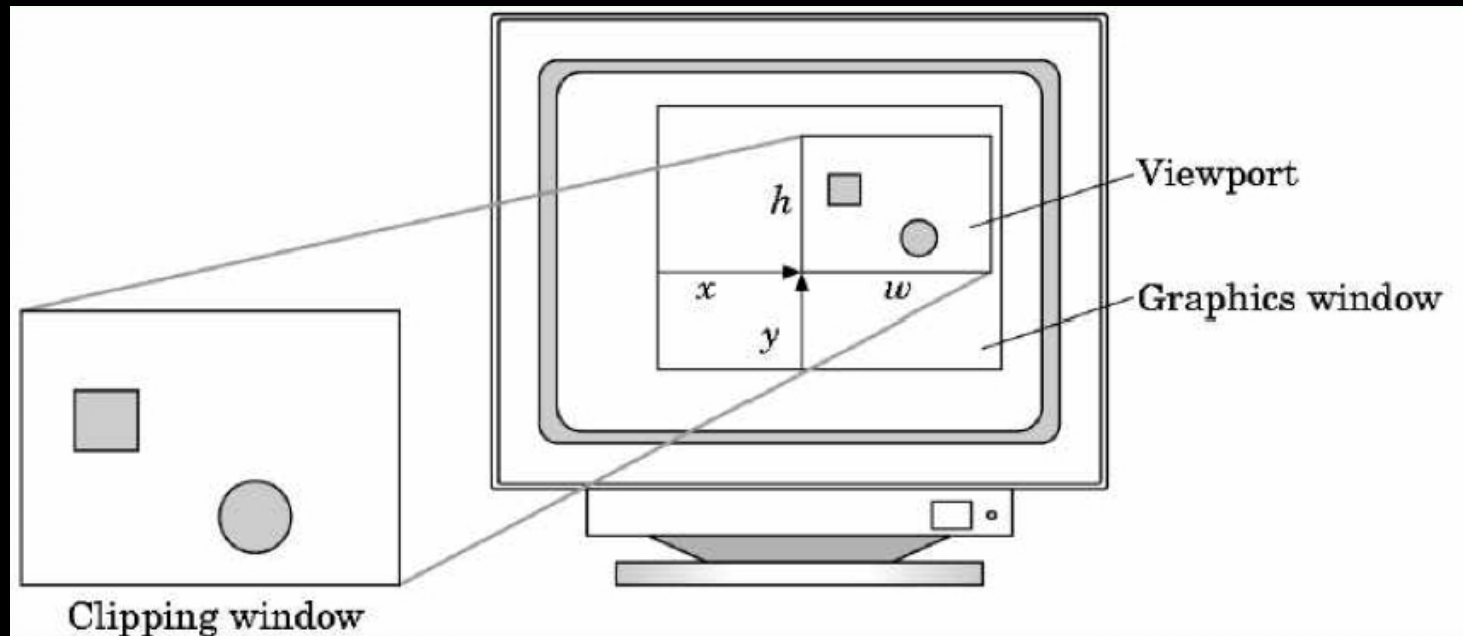

# Summary

1. A Graphics Pipeline
2. The OpenGL API
3. Primitives: vertices, lines, polygons
4. Attributes: color
5. Example: drawing a shaded triangle

